

The Soft Call Recorder

Have you ever thought of recording all your telephone calls fully automatically? Maybe you have, but chances are you never found the right solution.

A PC equipped with one or more Soft Call Recorders is the ideal means of recording telephone calls. The computer has no problem coping with archives of tens of thousands - maybe even hundreds of thousands - of telephone calls and the thousands of hours of recording time involved. Imagine trying to store all these telephone calls on cassettes....

Recording telephone calls

If you are doing important business by telephone, one day you will be very glad to have a recording of a conversation. These are some facts about recording telephone calls:

- Recording telephone calls is normal practice in many organisations, both businesses and government bodies. The conversations held with them are recorded so that there is proof of agreements reached.

- An oral agreement, including one made on the telephone, is legally binding. If such an agreement is later challenged, it will be difficult to find evidence. If the telephone call was recorded you will have no difficulty doing so.

- A recording of a telephone call is generally accepted as evidence. Thanks to this recording you will prove your case.

- The hard disk of a modern PC has extra space for at least 2400 hours of recorded telephone calls (10Gb), not including your own data already stored on it.

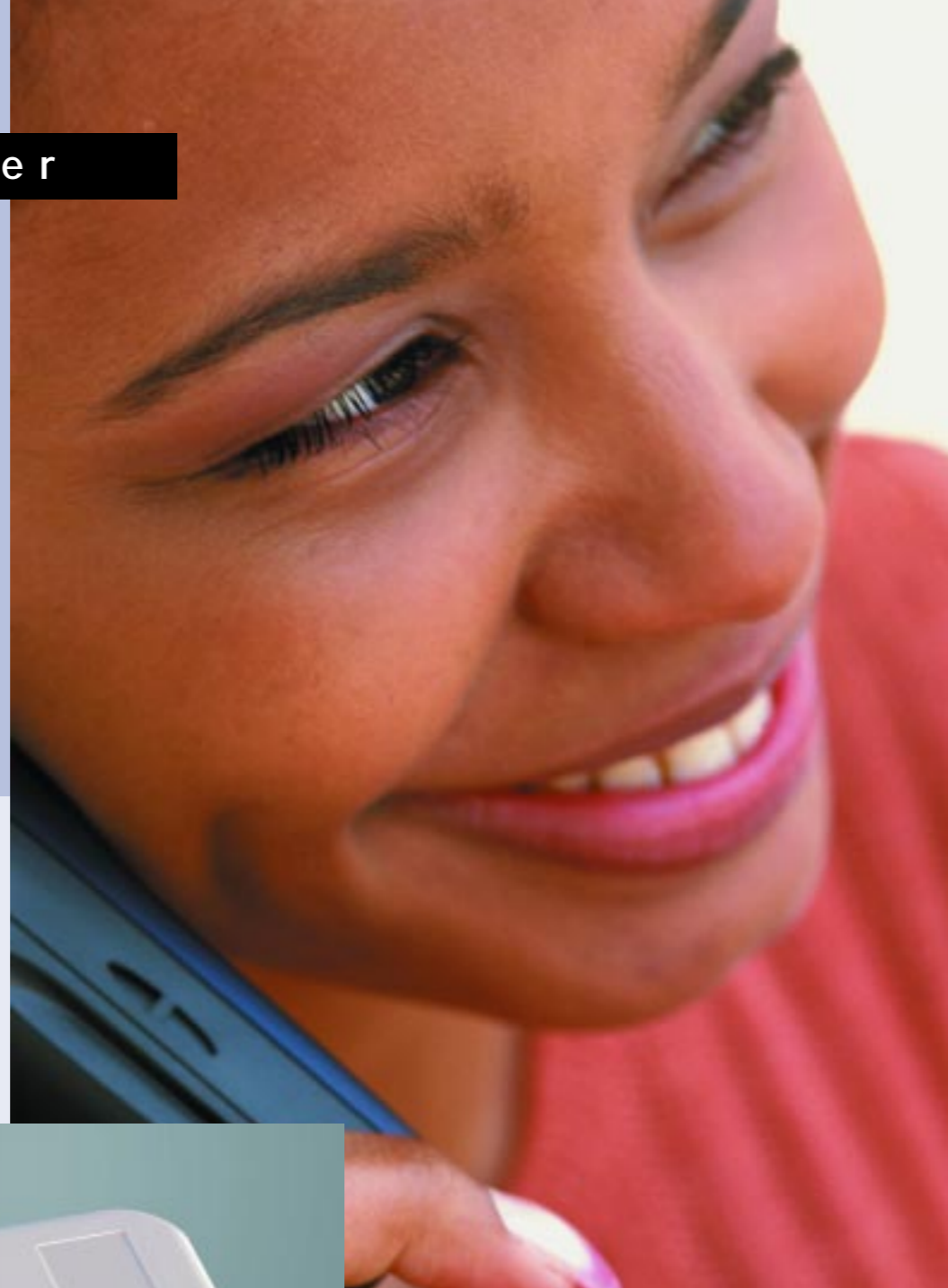

A very practical product

A Soft Call Recorder ensures that your PC records every telephone call fully automatically. Recording your calls does not involve any action by yourself, so you can never forget to record a telephone conversation. Erasing the calls after the conversation, or at any later moment, is always possible. The software that comes with the Soft Call Recorder will automatically create a database in which all recordings can be retrieved. You can search on name, time and date, or duration of the conversation.

Numerous applications

Many Call Recorders have been supplied over the years, and are in general use with a wide number of bodies:

- Banks and other financial institutions
- Call-centres
- Businesses
- Firms dealing with the general public, such as taxis, pizza deliverers, cinemas and theatres
- Private individuals with many business contacts

The Soft Call Recorder has been specially designed as a less expensive alternative to the normal Call Recorder. Thanks to our long experience with providing stand-alone Call Recorders, we are able to offer exactly those features needed to make the application of the Soft Call Recorder successful.

Unique features

The features that guarantee maximum benefits of the Soft Call Recorder are:

- Full automatic recording: recording is fully automatic based on detection of the hook contact or voice activation.
- High capacity: thanks to our formidable compression technique, several thousand hours of telephone calls - in practice this means all your calls - can be effortlessly stored.
- High quality of recording: the Soft Call Recorder combines high compression with excellent sound quality.
- Simultaneous recording from more than one line is possible: using a standard USB hub up to six Soft Call Recorder USB can be connected to a PC, so that simultaneous recording from six telephone lines is possible.

Rapid payback

As the Soft Call Recorder automatically stores every call, you can be sure to have the recording when you really need it. Late delivery, a higher price than agreed, or a wrong colour ... you will have a strong case! The Call Recorder will soon pay for itself!

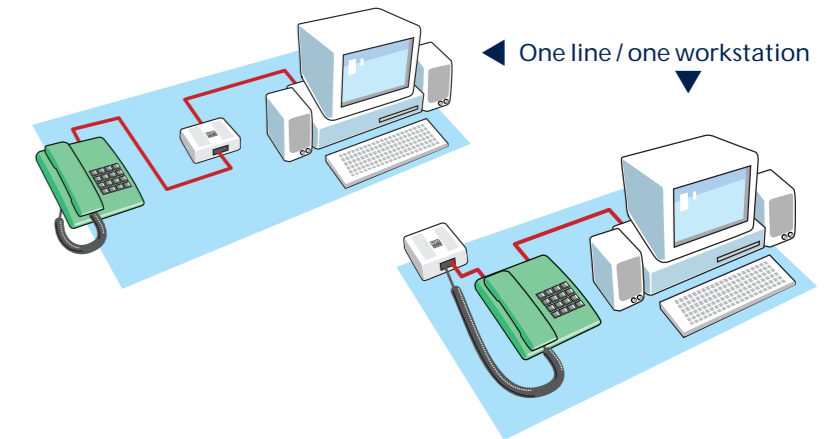

Specialised Software

The software supplied has been specially developed to deal with and archive the large number of recordings made by the Soft Call Recorder. It offers the following functions:

- Extensive select and search function: it is easy to make selections based on, for instance, name, date or telephone number.
- Export and conversion routines: certain telephone calls or whole selections can be exported onto CD-ROM archive and/or converted into a PC-WAVE format that can be played on any PC. Ideal for when you want to send someone a call on a floppy or as an e-mail.
- Presentation can be configured by the user: You can determine exactly how the software should present the data.

Central archiving via a network

An important function of the software supplied is combining separate archives into one via a network. This creates one centralised archive of the telephone calls of different people or from different telephones. The use of several Soft Call Recorders on one network therefore performs the same function as a centrally situated voice logging system, at very little cost.

Centralised archiving across the network

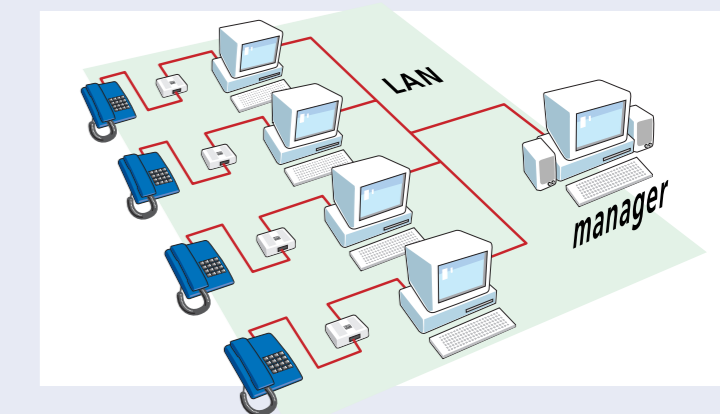

Technical Specifications Soft Call Recorder Classic	
Article number	1165
Included	Soft Call Recorder Classic Cable to telephone - 0.8 metre 2 x cable to sound card - 3 metres CD with software Manual
System requirements	Pentium PC 350Mhz or better Microsoft Windows 95/98/ME/NT4.0/2000 SB16 compatible sound card
Connections	Type Connector
Signal out	Mini-jack 3,5 mm
Signal in	Mini-jack 3,5 mm
Signal out for Loudspeakers	Mini-jack 3,5 mm
Handset or line	RJ10
Handset or line	RJ11

Technical Specifications Soft Call Recorder USB	
Article number	1168
Included	Soft Call Recorder USB Cable to telephone - 0.8 metre Cable to USB port - 2,5 metres CD with software Manual
System requirements	Pentium PC 350Mhz or better Microsoft Windows 98/ME/2000 USB port free, direct or via hub Loudspeakers
Connections	Type Connector
Signal out for Loudspeakers	Mini-jack 3,5 mm
USB	
Handset or line	RJ10
Handset or line	RJ11
USB product ID	PID = 4609
USB vendor ID	VID = 3553

Technical Specifications for both models (1165 & 1168)	
Coding method	Bytes/sec
Digitalk 8.5	1062,5
ADPCM	4000
Sizes (L/B/H)	7 x 6,6 x 2,8 cm
Weight	About 85 gram
Technical norms	
EU Telecommunication	CTR21
EU Telecommunication country specific norms	ATAAB & National Advisory Notes
EU safety	EN50081 part 1, EN50082 part 1, EN60950
EU Emission	CE
USA Telecommunication	FCC part 68, subpart D
USA Emission	FCC part 15, subpart B



Two models

The Soft Call Recorder can be supplied in two models: the Classic, to be connected to the sound card, and the Soft Call Recorder 'USB', which does not require a sound card.

Soft Call Recorder Classic

This model Call Recorder is connected to one of the audio inputs of the PC sound card. Thanks to a unique detection circuit the recorder will tell the PC when the telephone rings, is taken off the hook and put back on again. When used with an analogue line it determines precisely when a call starts and when it finishes. This Soft Call Recorder does not require a USB port. It is therefore suitable for PC's and notebooks with all versions of Microsoft Windows from Win95 and later.



▲ Classic

Soft Call Recorder USB

This model is either connected directly to the USB port of the PC, or via a hub. The PC will therefore not require a sound card. The Soft Call Recorder records the sound digitally straightaway. If necessary, loudspeakers can be connected directly to the Soft Call Recorder to reproduce the sound. This Soft Call Recorder can also either be connected to the telephone receiver or to the telephone line, and detects the telephone ringing as well as it going on or off

▼ USB

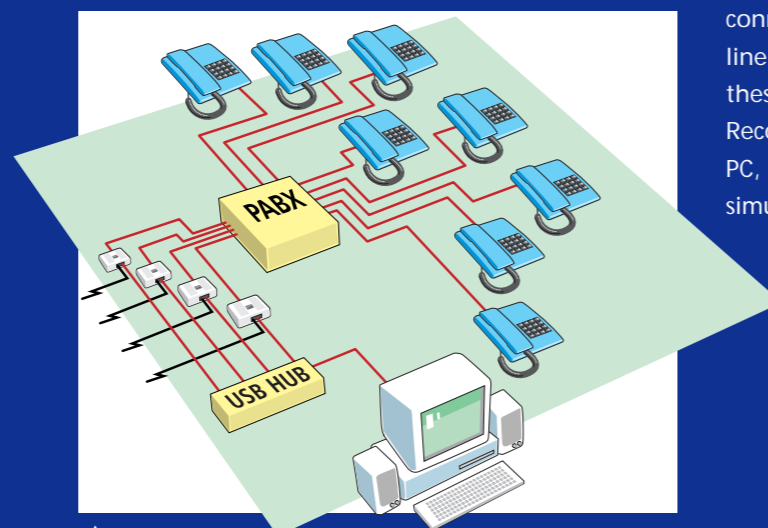

▲ Recording from multiple telephone lines using Soft Call Recorder USB

the hook when connected to the line. Up to six of these Soft Call Recorders can be connected to one PC, with the possibility of recording simultaneously from all lines.

Soft Call Recorder

Records telephone calls onto the hard disk of your PC

Has an almost unlimited capacity

Can record from several lines at once (USB)

Comes in a complete package: hardware, software and cables



Restrictions	
Privacy protection	The Soft Call Recorder may not be used to record conversations unless at least one of the speakers is aware of this. The business user should be aware of the Act on Personal Registration and is responsible for ensuring the Soft Call Recorder is used in agreement with this Act. When in doubt he should contact the Registration Office.
Warning	Other software used by the same PC can harm the recording quality.
Guarantee	2 years guarantee on the hardware Guarantee on the software is restricted to the correct functioning of a standard system indicated by the manufacturer.
Liability	The manufacturer and his retailers do not accept liability for the loss of data and the possible consequences of this for the user.

Other Call Recorders

We supply various models of Call Recorder with internal hard disk that work independently of a PC. These Call Recorders can exchange recordings with the PC environment via networks. If you are interested, we will gladly send you more information.

A product of Vidicode Datacommunicatie BV



Vidicode Datacommunicatie BV

tel.: +31(0)79 3617181
www.vidicode.nl

fax: +31(0)79 3618092
vidicode@vidicode.nl